



DESIGN REVIEW BOARD APPLICATION

Administered by: Design Review Board

Property Address\*: 694 Riverside Drive
Applicant Name & Mailing Address: Graves Oil Company 226 Pearson St, Ms. Batesville 38606
Applicant Phone Number: 662-563-4604 Applicant Fax Number:
Property Owner's Name & Mailing Address: Riverside Dr. Enterprises LLC 1408 Pecan Trees Ln Germantown TN 38138
Property Owner's Phone Number:

The proposed work consists of the following (check all that apply):

- Sign [checked] Renovation [ ]
New Building [ ] Other Exterior Alteration [ ]

Project Description: ON gas canopy, remove existing BP image and install exxon image with red & white canopy fascia. Install 2 sets lighted channel letters reading Exxon.

Status of Project: Double pole sign - remove existing BP signage and install exxon signage. Will have a 2'x5' full color electronic message center below exxon signage

ready to proceed

A complete application must be submitted to the Development Department no later than two weeks before a regularly scheduled meeting of the Design Review Board. Please contact Brett Roler at (901) 575-0574 or roler@downtownmemphis.com.

Owner/Applicant Signature: Chuck Crawford
Date: 3-27-17

\*Applications for properties that are located within a Landmarks Historic District may require additional approval from the Landmarks Commission. Please contact Nancy Jane Baker at (901) 576-7170 for more information.

EXISTING



regular 249<sup>9</sup>  
diesel 248<sup>9</sup>

BP gasoline *invigorate*

hot food • atm  
LOCALLY OWNED

AIR



# Exxon Sign System

New 56" x 73-1/4" Exxon ID TP Sign

Exxon - Embossed

Synergy

New 56" x 73-1/4" 2P LED TP Price Sign

Regular - 16" Red Dak FL-3000 LEDs

Diesel - 12" Green Dak FL-3000 LEDs

Note: EMprint Semibold font style

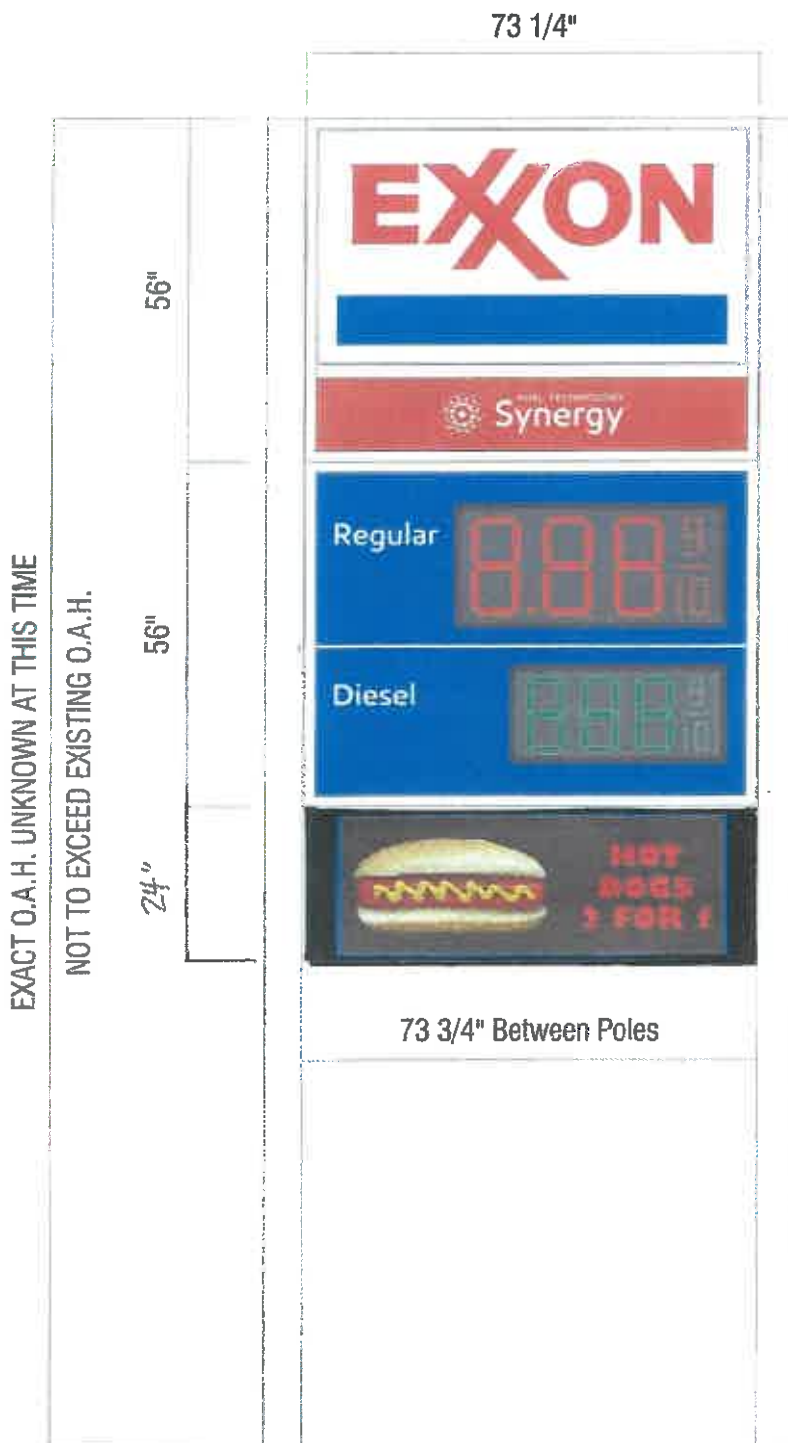

# PROPOSED



VISUAL COMMUNICATIONS

www.FederalHealth.com

1251 Washington St Suite 245 Grafton, WI 53024  
262.377.2975 - Phone 262.377.3193 - Fax

#### Manufacturing Facilities:

Oceanside - Euless - Jacksonville - Columbus

#### Office Locations:

Oceanside - Las Vegas - Laughlin - Idaho Falls

Euless - Jacksonville - Houston - San Antonio

Corpus Christi - Grafton - Milwaukee

Willowbrook - Louisville - Indianapolis - Columbus

Cincinnati - Westerville - Knoxville - Turin

Atlanta - Tampa - Daytona Beach - Winter Park

**Building Quality Signage Since 1901**

#### Revisions:

1	
2	
3	
4	
5	
6	
7	

#### Account Rep:

Project Manager: **Elissa Williams**

Drawn By: **Brenda Lammers**

#### Project / Location:

**ExxonMobil**

694 Riverside Dr.  
Memphis, TN

This original drawing is provided as part of a planned project and is not to be exhibited, copied or reproduced without the written permission of Federal Health Sign Company LLC or its authorized agent.

Job Number: **Ex170886.E**

File Name:

Date: **02.06.17**

Sheet Number: **1** of **1**

Design Number:

Approved  Approved w/changes

Signature

Date

# Exxon - ACM Logo Box 2D Canopy Fascia

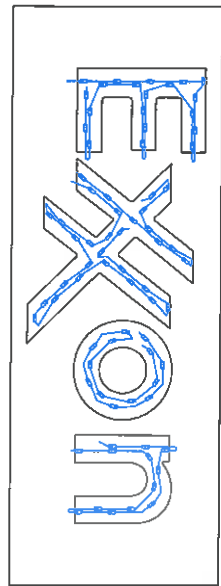

Exxon - LED Layout

**ELECTRICAL INFORMATION:**  
 (78) LED SLOAN V180 MINI 8500K HB (70128-6MMW2-4MB) = 31"  
 (1) POWER SUPPLY SLOAN (701507-4MODW) MOD 60-W 12VDC 1.0 AMPS EA

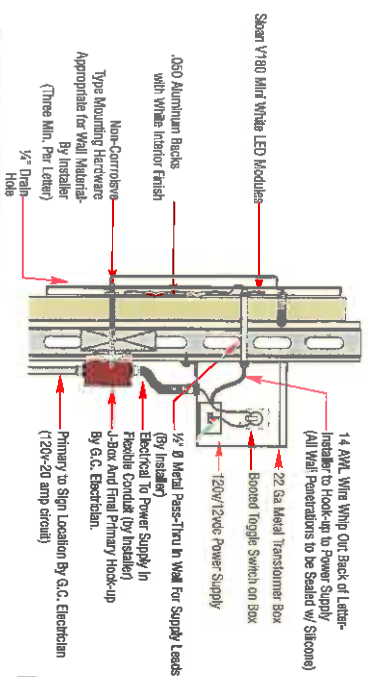

**ELECTRICAL REQUIREMENTS:**

Total: 1 Amps

# of 120V, 20A Circuits Req'd T.B.D.

ALL BRANCH CIRCUITS SHALL BE DEDICATED TO SIGNS (INCLUDING GROUND AND NEUTRAL), AND SHALL NOT BE SHARED WITH OTHER LOADS.



Exxon - ACM Logo Box Assembly



Exxon - Vacuum Formed Letterset

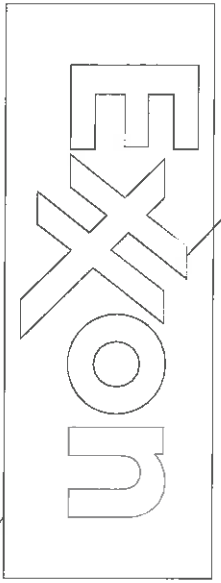

Exxon - ACM Letter Box

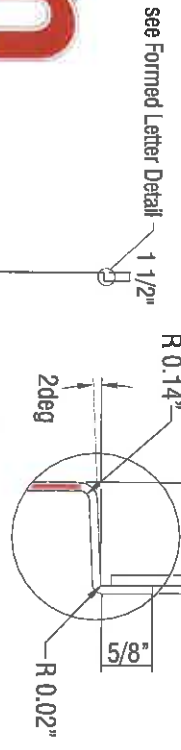
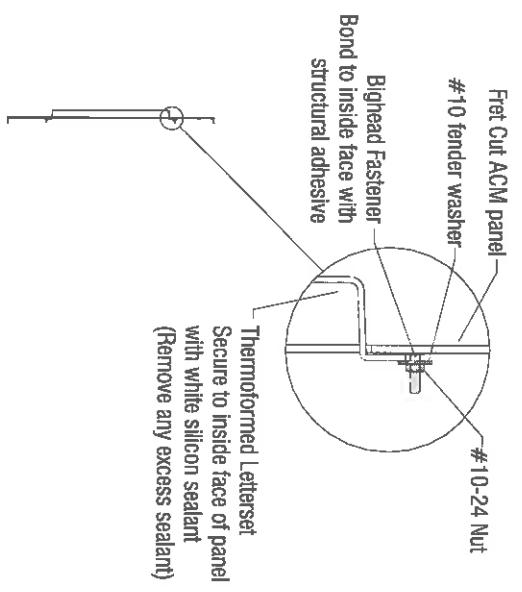

Letterset thermofomed from translucent white polycarbonate. Translucent red vinyl applied first surface.

Fret Cut Letters Minimum Offset:

White ACM Panel (gloss side out)  
 Alpollic - Saw White 3mm [0.118"]

**FEDERAL HEATH SIGN COMPANY**  
 www.federalheath.com  
 1500 North Bellin Jacksonville, FL 32218  
 (904) 589-2100 (800) 886-1327 Fax (904) 589-2101

**ADDED LED INFORMATION KH 4/22/16**

THIS DRAWING IS YOUR FINAL PROOF. IT SUPERSEDES ALL VERBAL AND WRITTEN COMMUNICATION BY SIGNING BELOW YOU ARE AUTHORIZING US TO MANUFACTURE TO THE ABOVE SPECIFICATION

Client Approved/Date: \_\_\_\_\_

Account Rep: \_\_\_\_\_  
 Project Manager: **Peggy Debeck**  
 Design By: **Gda**

**ExxonMobil**

Project / Location: \_\_\_\_\_

Job Number: **EX162234**  
 Date: **04.08.16**  
 Sheet Number: **1** of **1**  
 Design Number: \_\_\_\_\_

This original drawing is provided as part of a planned project and is not to be exhibited, copied or reproduced without the written permission of Federal Health Sign Company, LLC or its authorized agent.

RIVERSIDE



CAROLINA

**Measurement**



Feet



Measurement Result

134.18 Feet



CENTER CITY  
COMMISSION

July 12, 2007

Mr. Scott Peck  
Peck Signs  
1558 Texas Road  
Memphis, TN 38106

RE: Signage Approval  
BP Gas Station, 694 Riverside Drive  
Case 07-56

Dear Mr. Peck:

On July 12, 2007, the Center City Commission Design Review Board (DRB) approved your application for signage at the above referenced location. This approval allows the installation of a new sign faces on an existing legal nonconforming pole sign. The sign will be modified to identify the new operator- BP Gas Retail Center. The proposed modified/new sign measures 25' in height, with a sign face measuring approximately 16'(H) X 6'(W), which equals approximately 96sf. The sign will be internally illuminated (fluorescent tubes) and will identify the gas station, list gasoline prices, list an ATM provider, and include a reader-board (changeable copy).

This approval allows you to proceed with permit applications from the Memphis and Shelby County Office of Code Enforcement and other applicable bodies. Thank you for your investment in Downtown Memphis.

Sincerely,

  
Jaske' Goff  
Development Project Manager

CC: Larry Jenkins  
John Gary

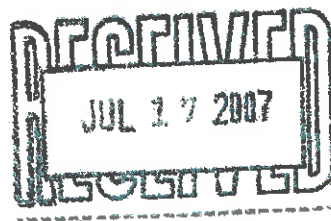

The Crump Building  
114 North Main Street  
Memphis, TN 38103  
901.575.0540  
Fax 901.575.0541  
[www.downtownmemphis.com](http://www.downtownmemphis.com)

CENTER CITY  
REVENUE  
FINANCE  
CORPORATION

CENTER CITY  
DEVELOPMENT  
CORPORATION

DESIGN  
REVIEW  
BOARD

DOWNTOWN  
PARKING  
AUTHORITY

50065894